

## PLANAR ANTENNA

### FOR TRAINBORNE WIRELESS COMMUNICATION

#### Mounting Instruction



Keep away from catenary and high voltage lines.  
Be careful when working at height!  
Always secure ladders!  
Always tighten screws!

If exposed to extreme environmental conditions, especially polluted atmosphere, the connectors should be covered with a self-vulcanising tape or a cold shrink tube.

Dimensions in millimetre [mm]

Only authorized and trained field service personal is permitted to install the antenna.

The roof of the vehicle should offer a sufficient mechanical stability to prevent leakage into the vehicle.

1) Choose the installation routing using the largest bend radii possible. Small bend radii may affect electrical performance. Exceeding the specified limits during the installation process could cause a permanent degradation. The minimum bending radius for static and repeated applications are respectively 24.75 and 74.25 mm.

2) The cable has to be mounted on the train in such a way that it is protected against any damage from environmental influences.

3) Avoid twisting microwave cable assemblies. Torsion of this type of assembly can alter the relative diameters of cable layers and affects the electrical characteristics. Exceeding the limit of 10° per metre during installation process cause a permanent degradation.

4) Mounting screws are not included. The indicated torque is given assuming the antenna installed on a 8mm thick steel mounting plate with M6 cylinder head screws according to ISO 4762 and a minimum length of 12mm.

According to the NF F16-102 standard (see chapter 6.1), this antenna can be fitted outside (or in a technical compartment) the vehicle and complies with the following requirements: Requirements 0, whatever the category of the rolling stock. Requirements 0 (see Table 1, chapter 6, NF F 16-102) stipulate that "no requirements" are necessary. For installations inside the vehicles, this antenna has to be kept away from passengers and fitted inside a technical compartment (see chapter 6.2) separate by a fire retardant partition.

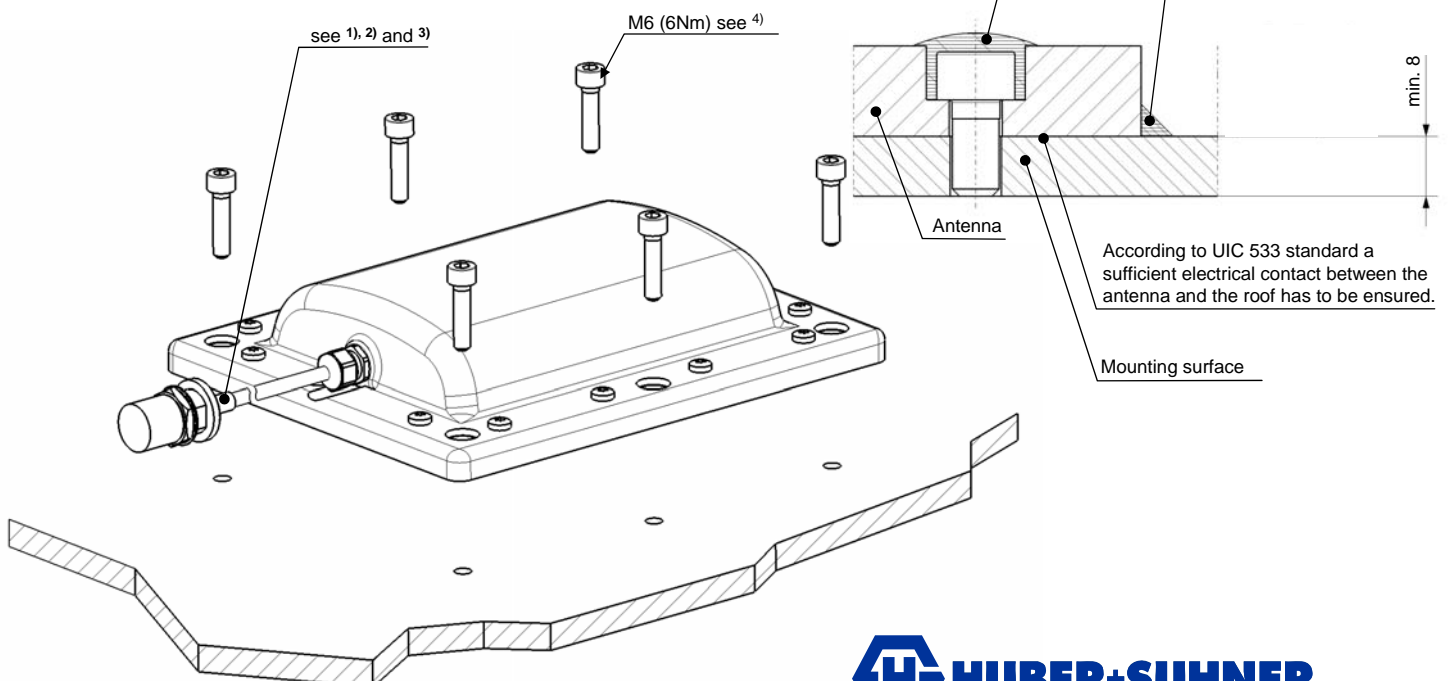

HUBER+SUHNER is certified according to ISO 9001 and ISO 14001

#### WAIVER!

It is exclusively in written agreements that we provide our customers with warrants and representations as to the technical contained specifications and/or the fitness for any particular purpose. The facts and figures herein are carefully compiled to the best of our knowledge, but they are intended for general informational purposes only.



**HUBER+SUHNER AG**

**RF Technology**

**9100 Herisau, Switzerland**

Phone +41 (0)71 353 41 11

Fax +41 (0)71 353 47 51

www.hubersuhner.com

Doc. No. 0000250348

Art. No. 84036179

Revision B

HUBER+SUHNER – Excellence in Connectivity Solutions